

# Purge Valves

## Applications

**SUPERLOK** purge valves are manual bleed, vent, or drain valves. One-quarter turn with a wrench from finger-tight obtains leaktight closure on first makeup. Snugging with a wrench ensures closure to the rated pressure with subsequent makeups.

## Features

- Compact for convenient installation.
- Vent hole is bled excessive liquid or gas from system lines.
- Cap is crimped to valve body to prevent accidental disassembly.
- Variety of end connections; **SUPERLOK** tube fittings, NPT and ISO threads.

## Caution

When installing a **SUPERLOK** purge valve, position the vent hole to direct system fluid away from operating personnel. The vent hole rotates with the cap. Changing the direction of discharge as the cap is turned. Always open purge valves slowly. These valves contain no packing, so some fluid weepage will occur when the valves are opened. Operating personnel must protect themselves from exposure to system fluids.

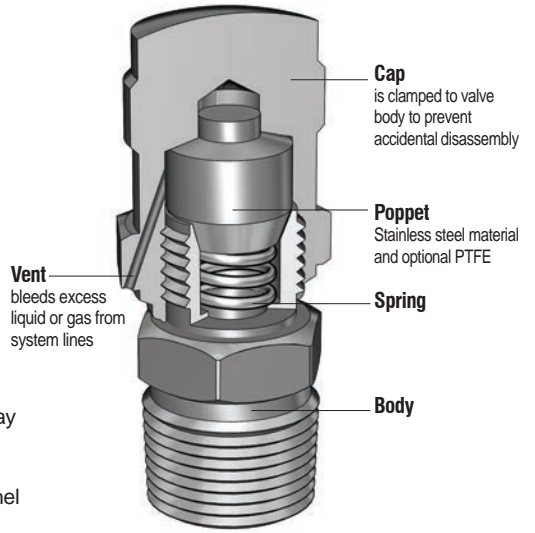

## Materials of Construction

Component	Valve Body Materials
	Material Grade/ASTM Specification
Cap	316 SS / A276
Body	316 SS / A276
Poppet	316 SS / A276
Spring	304 SS

## Technical Data

Series	Pressure - Temperature Rating	
	Temperature °F (°C)	Working Pressure psig (bar)
SPUV	-65 to 600°F (-54 to 315°C)	4,000psig (275bar) @ 100°F (38°C)

## Pressure - temperature ratings

Material	316 SS
Temperature °F (°C)	Working Pressure, psig (bar)
-65(-53) to 100(37)	4,000(275)
150(65)	3,720(256)
200(93)	3,440(237)
300(148)	3,105(213)
350(176)	2,975(204)
400(204)	2,850(196)
450(232)	2,750(189)
500(260)	2,650(182)
600(315)	2,500(172)

## Table of Dimension

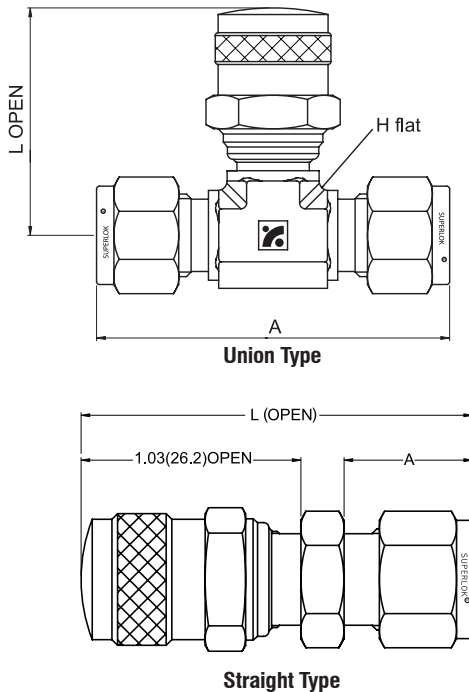

## Union Type

Part Number	Inlet End Connection	Dimensions in.(mm)		
		L	A	H
SPUV S4-UT	1/4" SUPERLOK	1.49(38.0)	2.26(57.5)	0.63(15.9)
SPUV S6-UT	3/8" SUPERLOK	1.49(38.0)	2.40(61.0)	0.63(15.9)
SPUV S8-UT	1/2" SUPERLOK	1.61(41.0)	2.82(71.6)	0.81(20.6)

## Straight Type

Part Number	Inlet End Connection	Dimensions in.(mm)	
		L	H
F2N	1/8" Female NPT	1.56 (39.6)	0.53 (13.5)
F4N	1/4" Female NPT	1.75 (44.4)	0.72 (18.3)
F6N	3/8" Female NPT	1.81 (46.0)	0.78 (19.8)
F8N	1/2" Female NPT	1.98 (50.3)	0.97 (24.6)
M2N	1/8" Male NPT	1.62 (41.1)	0.38 (9.7)
M4N	1/4" Male NPT	1.81 (46.0)	0.56 (14.2)
M6N	3/8" Male NPT	1.84 (46.7)	0.56 (14.2)
M8N	1/2" Male NPT	2.09 (53.1)	0.75 (19.1)
S2	1/8" SUPERLOK	1.84 (46.7)	0.59 (15.0)
S4	1/4" SUPERLOK	1.94 (49.3)	0.69 (17.5)
S6	3/8" SUPERLOK	2.03 (51.6)	0.75 (19.1)
S8	1/2" SUPERLOK	2.19 (55.6)	0.88 (22.4)
S6M	6mm SUPERLOK	1.94 (49.3)	0.69 (17.5)
S8M	8mm SUPERLOK	2.00 (50.8)	0.72 (18.3)

Dimensions are for reference only, subject to change.

## Table of Dimension

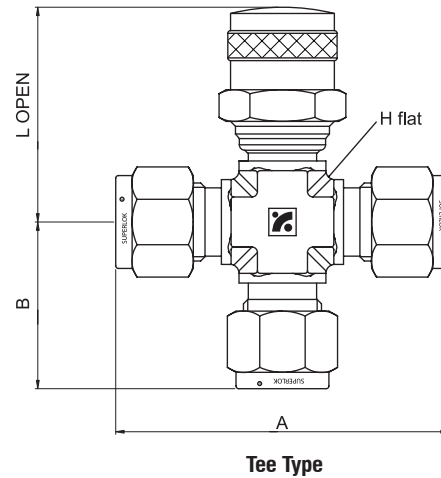
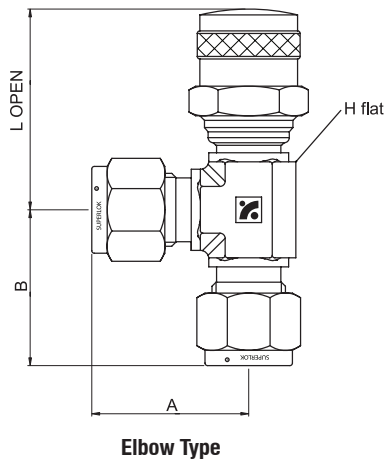

Part Number	Inlet End Connection	Dimensions in.(mm)				
		L	A	B	H	
SPUV	S4-ET	1/4" SUPERLOK	1.49 (38.0)	1.13 (28.8)	1.13 (28.8)	0.63 (15.9)
	S6-ET	3/8" SUPERLOK	1.49 (38.0)	1.20 (30.5)	1.20 (30.5)	0.63 (15.9)
	S8-ET	1/2" SUPERLOK	1.61 (41.0)	1.41 (35.8)	1.41 (35.8)	0.81 (20.6)

Part Number	Inlet End Connection	Dimensions in.(mm)				
		L	A	B	H	
SPUV	S4-TT	1/4" SUPERLOK	1.49 (38.0)	2.26 (57.5)	1.13 (28.8)	0.63 (15.9)
	S6-TT	3/8" SUPERLOK	1.49 (38.0)	2.40 (61.0)	1.20 (30.5)	0.63 (15.9)
	S8-TT	1/2" SUPERLOK	1.61 (41.0)	2.82 (71.6)	1.41 (35.8)	0.81 (20.6)

\* All dimensions in millimeters unless specified as "inch". Dimension are for reference only, subject to change.

## ordering information

Example : **SPUV - S 4 - UT - SS**

1
2
3
4
5

### 1. Valve Series

SPUV

### 2. End Connection

S : SUPERLOK Tube Fitting

F : Female Thread

M : Male Thread

### 3. End Connection Size

#### Tube O.D Designation

Tube O.D (inch)	1/4	3/8	1/2
Designation	4	6	8
Tube O.D (mm)	6	10	12
Designation	6M	10M	12M

#### Pipe Thread Designation

Size (inch)	1/8	1/4	3/8	1/2
BSPT	2R	4R	6R	8R
NPT	2N	4N	6N	8N

### 4. Pattern Designator

Nil : Straight Type

UT : Union Type

ET : Elbow Type

TT : Tee Type

### 5. Body Material

SS : 316 Stainless Steel

B : Brass